

Left side

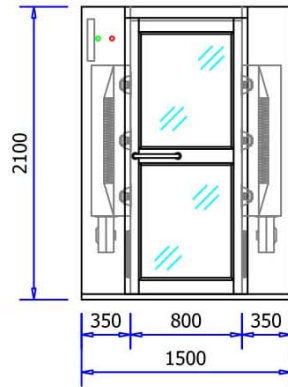

Front side

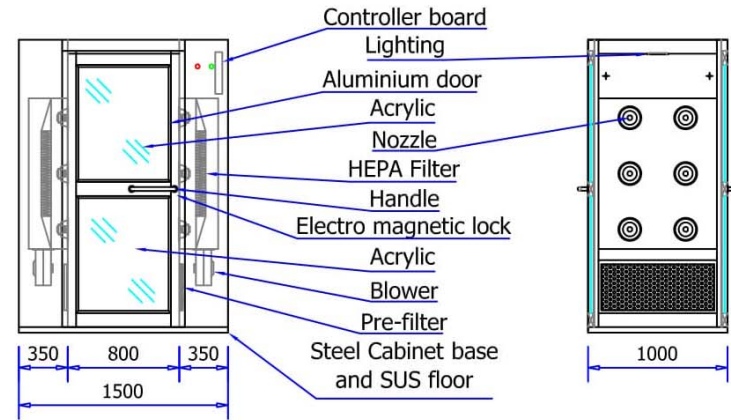

Back side

Right side

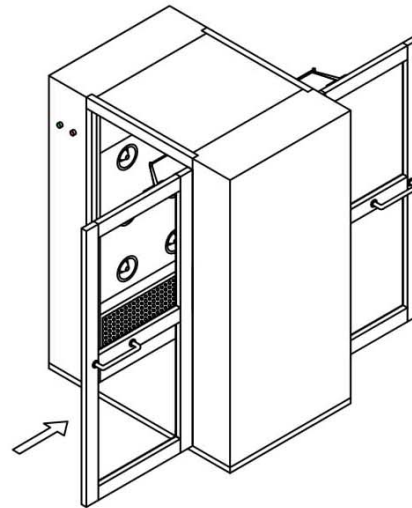
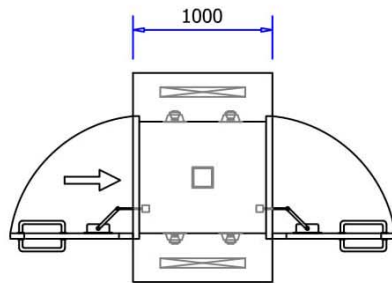

AS - 1500 - 1 (EG)
External Body : Electro-Galvanized Steel with powder coating
Internal Body : Electro-Galvanized Steel with powder coating
External Size : 1500(W) x 1000(D) x 2100(H)
Internal Size : 800(W) x 910(D) x 1960(H)
Main Filter : HEPA Filter 99.99 % on 0.3 micron
Fan Capacity : 700 CMH / unit
Nozzle : Stainless mirror 12 Pcs.
Type of airflow : 2 side blowing
Air Velocity : 22-23 m/s
Operation : PLC Control
Lighting : LED 9 W.
Door : Aluminium single swing door with clear acrylic

<p>SKILL DEVELOPMENT CO.,LTD. 109 M.7 KINGKAEW-BANGPLEE RD. BANGPLEEYAI BANGPLEE SAMUTPRAKARN 10540 บริษัท สกิล ดีเวลอปเม้นท์ จำกัด 109 หมู่ 7 ต.สีกัน-บางพลี พ.บางพลีใหญ่ อ.บางพลี จ.สมุทรปราการ 10540 Tel: 02-751-1256-8 Fax: 02-337-3364</p>	PROJECT NAME :	DRAWING TITLE :	SCALE : A4-1:100	DRAWING BY :	DRAWING DATE :
	OWNER :	ENGINEERS : สีกันย์ สุทธิสุวรรณ /18.9882	ISSUED / REVISION :	DRAWING NO. TOTAL	
SITE :	APPROVED BY : สีกันย์ สุทธิสุวรรณ	NO. DESCRIPTION BY DATE		DESIGN-01 00/00	
			NO./REV. : : xx/xx/xx		